



DELTA

Long-Distance Monitoring Communication Module
For VRF Air Conditioners

89COM-300A

INSTRUCTION MANUAL

WARNING!

Read and follow all safety precautions in Instruction Manual - improper use can cause serious injury.

CONTENT

1. Brief Introduction to the Function	1
2. Structure Diagram	1
3. Operation Instruction	1
3.1 Interface	1
3.2 Indicating Lamps	1
3.3 DIP Switch	2
3.4 “ON/OFF” Press Button	3
3.5 Installation Diagram	4
3.6 How to Connect the Crystal Head	5
4. Precautions	5
5. Comparison Table of the Address Codes	6
6. Appendix A. Marking Description	7

1. Brief Introduction to the Function

The communication module is intended to exchange and transfer communication data between the monitoring computer (or the building management system) and the air conditioning system.

2. Structure Diagram

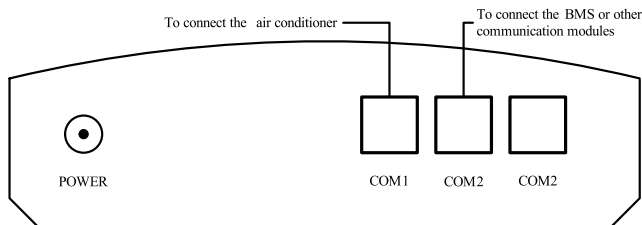

Fig.1 Interfaces

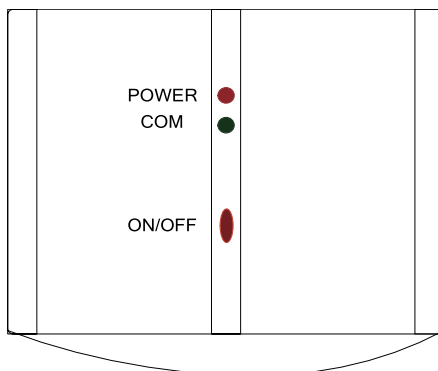

Fig.2 Indicating Lamps

3. Operation Instruction

3.1 Interface

3.1.1 Power Supply Interface

As shown in the Fig.1, it is recommended generally to use the adaptor provided by DELTA. And other kind of 9~12VAC, 800mA power supply is also alternative but the interface should be compatible.

3.1.2 Communication Interface

As shown in the Fig.1, one COM1 interface is used to connect the air conditioner to realize the communication between the communication module and the air conditioner; two COM2 interfaces are used to connect the monitoring computer (or the building management system); and RS232 is reserved.

3.2 Indicating Lamps

3.2.1 Power Supply Indicating Lamp

As shown in the Fig.2, the red LED is the power indicating lamp. When the lamp is on, it means the communication module is powered normally; if it is off, it means that the communication module is powered abnormally.

3.2.2 Communication Indicating Lamp

Shown in the Fig.2, the green LED is the communication indicating lamp.

①. When this lamp is on, it indicates the communication goes well between the communication module and the air conditioning system, and also between the communication module and the monitoring computer (or the building management system).

②. When this lamp is off, it indicates the communication goes wrong between the communication module and the air conditioning system, and also between the communication module and the monitoring computer (or the building management system).

③. When the indicating lamp flashes twice every two seconds, it indicates the communication between the communication module and the air conditioning system goes wrong but the communication between the communication module and the monitoring computer (or the building management system) goes well.

④. When the indicating lamp flashes once every two seconds, it indicates the communication between the communication module and the monitoring computer (or the building management system) goes wrong but the communication between the communication module and the air conditioning system goes well.

3.3 DIP Switch

Please cut off the power supply of the communication module prior to any operation on the DIP switch.

3.3.1 How to Set the DIP2

DIP2 switch, located in the bottom case where is marked with “DIP2”, is composed of four toggle switches. When the toggle is placed to the end “ON”, it indicates “0”; when it is placed to the opposite end, it indicates “1”. For the time being, the DIP 2 switch is reserved with all toggles placed to the end “ON”. See the Fig.3 for how to set the DIP2 switch.

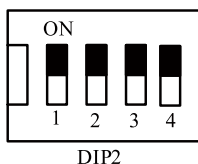

Address Code 0~15 (DIP 2)				
1	2	3	4	Add. Code
0	0	0	0	0
1	0	0	0	1
0	1	0	0	2
1	1	0	0	3
0	0	1	0	4
1	0	1	0	5
0	1	1	0	6
1	1	1	0	7
0	0	0	1	8
1	0	0	1	9
0	1	0	1	10
1	1	0	1	11
0	0	1	1	12
1	0	1	1	13
0	1	1	1	14
1	1	1	1	15

Fig.3 How to Set the DIP2

3.3.2 How to Set the DIP1

DIP1 switch, located in the bottom case where is marked with “DIP1”, is composed of eight toggle switches and is intended to set the Modbus address from 1 to 255. When the toggle is placed to the end “ON”, it indicates “0”; when it is placed to the opposite end, it indicates “1”. See the Fig.4 for how to set the DIP1 switch and also the real image.

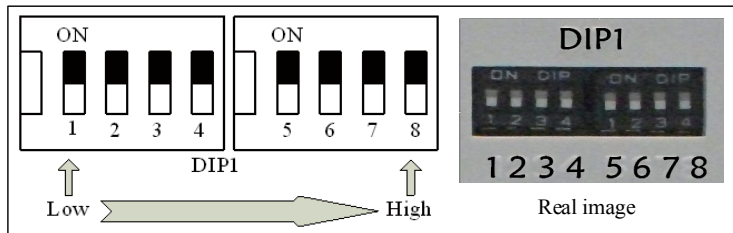

Fig.4 How to Set the DIP1

Examples for How to Set the Address :

① . See the Fig.5 for how to set the address 11

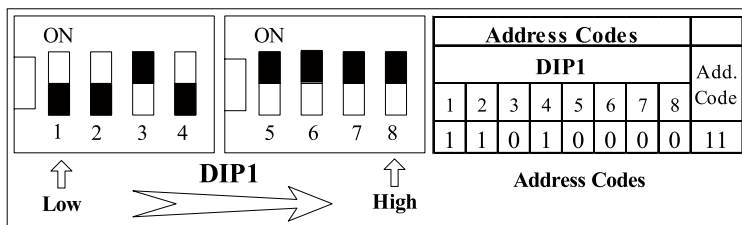

Fig.5 How to Set the Address 11

② . See the Fig.6 for how to set the address 43

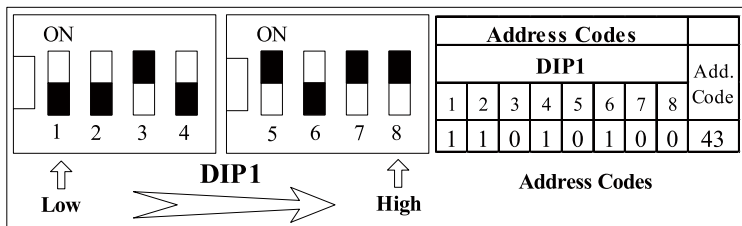

Fig.6 How to Set the Address 43

3.3.3 Check of the Address Setting of the Communication Module

After the address setting of the communication module is finished, it is necessary to check if this setting is correct through the monitoring computer or the centralized controller. On condition that both the monitoring computer and the centralized controller work normally but it fails to find the set address of the communication modules, it indicates that the setting is incorrect and it has to be reset by referring to section 5 Comparison Table of the Address Codes.

3.4 “ON/OFF” Press Button

The operation of this press button is reserved.

3.5 Installation Diagram

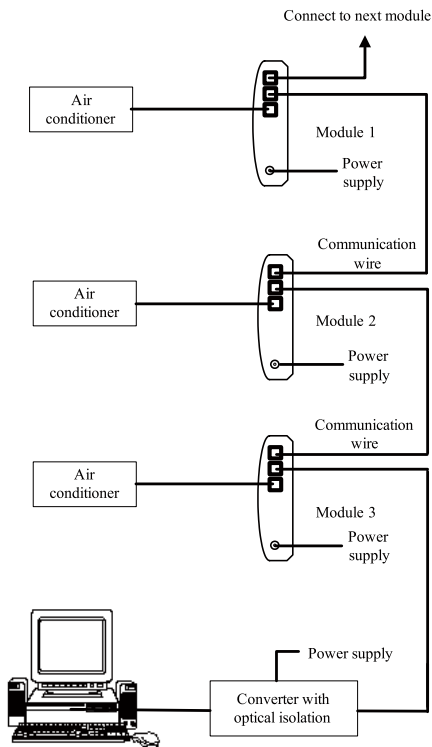

Fig.7 Installation Diagram

Notes:

①. The address range is 1~255 and should be unique; otherwise the communication would go wrong. (The address can not be set to 0, that is, all toggles of the DIP1 switch shall not be placed to “ON” at the same time.)

②. One communication cord (the two-core twisted pair with a length of one meter and with two crystal heads at each end) used for the connection between modules is provide by DELTA. Besides, the user can prepare the extension line in accordance with the actual need of the installation project.

③. One communication cord (the two-core twisted pair with a length of three metes and with one crystal head at one end and a four-core plug at the other end) used for the connection between the communication module and the air conditioner is provided by DELTA. Besides, the user can prepare the extension line in accordance with the actual need of the installation project; however, the users have to connect the crystal head by themselves. The four-core plug is used for connecting the four-core socket on the main board of the air conditioner and the crystal head is used for connecting the interface COM1. See the electric wiring diagram for more details.

④. The interface for the communication cord and the converter with optical isolation is A--R+/D+ (or 485+) B--R-/D-(or 485-).

⑤. When the communication module is used for the building management system which is developed by the other manufacturer rather than DELTA, the communication protocol for the relevant model can be claimed freely from DELTA.

⑥ . Non-polarity technology is adopted for the connection between the communication module and the monitoring system. Five seconds after the communication module is powered on, the monitoring system shall send out a command to confirm the polarity of the interface 485. Once the communication goes normally and stably, the monitoring system shall send such a command with an interval of less than one minute.

3.6 How to Connect the Crystal Head

The buckle of the crystal head should be downwards. The way to connect the crystal head is: peel off the insulating coat of the communication cord for a certain proper length, cut the end of the cord flush, and then insert the line A and line B of the four-core or two-core twist pair communication cord to the middle of the crystal head, after that, compress the crystal head to make the communication cord in the right place as shown in the Fig.8.

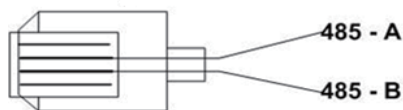

Fig.8 How to Connect the Crystal Head COM1/COM2

4. Precautions

① . Make sure the power supply and the four-core communication cord connected between the communication module and the main board is in good condition; otherwise the communication module would work abnormally and even be damaged.

② . Make sure the toggle of the DIP switch is placed to the right place; otherwise the communication would go wrong.

③ . Make sure the communication cord is connected to the proper interface; otherwise the communication would go wrong.

④ . Working conditions required:

a. Temperature range: $-10\sim+60\text{ }^{\circ}\text{C}$

b. Relative humidity: $\leq 95\%$

⑤ . Installed in the electric control box and free of direct sunlight, rain, snow etc.

⑥ . The product is subject to change on specification without notice.

⑦ . The communication module would go wrong if the working conditions are beyond the requirements mentioned above.

5. Comparison Table of the Address Codes

Table.1

Address Codes 0-31								
DIP1								Addr. Code
1	2	3	4	5	6	7	8	
0	0	0	0	0	0	0	0	0
0	0	0	0	0	0	0	0	1
0	1	0	0	0	0	0	0	2
1	1	0	0	0	0	0	0	3
0	0	1	0	0	0	0	0	4
1	0	1	0	0	0	0	0	5
0	1	1	0	0	0	0	0	6
1	1	1	0	0	0	0	0	7
0	0	0	1	0	0	0	0	8
1	0	0	1	0	0	0	0	9
0	1	0	1	0	0	0	0	10
1	1	0	1	0	0	0	0	11
0	0	1	1	0	0	0	0	12
1	0	1	1	0	0	0	0	13
0	1	1	1	0	0	0	0	14
1	1	1	1	0	0	0	0	15
0	0	0	0	1	0	0	0	16
1	0	0	0	1	0	0	0	17
0	1	0	0	1	0	0	0	18
1	1	0	0	1	0	0	0	19
0	0	1	0	1	0	0	0	20
1	0	1	0	1	0	0	0	21
0	1	1	0	1	0	0	0	22
1	1	1	0	1	0	0	0	23
0	0	0	1	1	0	0	0	24
1	0	0	1	1	0	0	0	25
0	1	0	1	1	0	0	0	26
1	1	0	1	1	0	0	0	27
0	0	1	1	1	0	0	0	28
1	0	1	1	1	0	0	0	29
0	1	1	1	1	0	0	0	30
1	1	1	1	1	0	0	0	31

Table.2

Address Codes 32-63								
DIP1								Addr. Code
1	2	3	4	5	6	7	8	
0	0	0	0	0	1	0	0	32
1	0	0	0	0	1	0	0	33
0	1	0	0	0	1	0	0	34
1	1	0	0	0	1	0	0	35
0	0	1	0	0	1	0	0	36
1	0	1	0	0	1	0	0	37
0	1	1	0	0	1	0	0	38
1	1	1	0	0	1	0	0	39
0	0	0	1	0	1	0	0	40
1	0	0	1	0	1	0	0	41
0	1	0	1	0	1	0	0	42
1	1	0	1	0	1	0	0	43
0	0	1	1	0	1	0	0	44
1	0	1	1	0	1	0	0	45
0	1	1	1	0	1	0	0	46
1	1	1	1	0	1	0	0	47
0	0	0	0	1	1	0	0	48
1	0	0	0	1	1	0	0	49
0	1	0	0	1	1	0	0	50
1	1	0	0	1	1	0	0	51
0	0	1	0	1	1	0	0	52
1	0	1	0	1	1	0	0	53
0	1	1	0	1	1	0	0	54
1	1	1	0	1	1	0	0	55
0	0	0	1	1	1	0	0	56
1	0	0	1	1	1	0	0	57
0	1	0	1	1	1	0	0	58
1	1	0	1	1	1	0	0	59
0	0	1	1	1	1	0	0	60
1	0	1	1	1	1	0	0	61
0	1	1	1	1	1	0	0	62
1	1	1	1	1	1	0	0	63

Address Codes 64-95								
DIP1								Addr. Code
1	2	3	4	5	6	7	8	
0	0	0	0	0	1	0	0	64
1	0	0	0	0	1	0	0	65
0	1	0	0	0	1	0	0	66
1	1	0	0	0	1	0	0	67
0	0	1	0	0	1	0	0	68
1	0	1	0	0	1	0	0	69
0	1	1	0	0	1	0	0	70
1	1	1	0	0	1	0	0	71
0	0	0	1	0	1	0	0	72
1	0	0	1	0	1	0	0	73
0	1	0	1	0	1	0	0	74
1	1	0	1	0	1	0	0	75
0	0	1	1	0	1	0	0	76
1	0	1	1	0	1	0	0	77
0	1	1	1	0	1	0	0	78
1	1	1	1	0	1	0	0	79
0	0	0	0	1	1	0	0	80
1	0	0	0	1	1	0	0	81
0	1	0	0	1	1	0	0	82
1	1	0	0	1	1	0	0	83
0	0	1	0	1	1	0	0	84
1	0	1	0	1	1	0	0	85
0	1	1	0	1	1	0	0	86
1	1	1	0	1	1	0	0	87
0	0	0	1	1	1	0	0	88
1	0	0	1	1	1	0	0	89
0	1	0	1	1	1	0	0	90
1	1	0	1	1	1	0	0	91
0	0	1	1	1	1	0	0	92
1	0	1	1	1	1	0	0	93
0	1	1	1	1	1	0	0	94
1	1	1	1	1	1	0	0	95



Address Codes 96-127								
DIP1								Addr. Code
1	2	3	4	5	6	7	8	
0	0	0	0	0	1	1	0	96
1	0	0	0	0	1	1	0	97
0	1	0	0	0	1	1	0	98
1	1	0	0	0	1	1	0	99
0	0	1	0	0	1	1	0	100
1	0	1	0	0	1	1	0	101
0	1	1	0	0	1	1	0	102
1	1	1	0	0	1	1	0	103
0	0	0	1	0	1	1	0	104
1	0	0	1	0	1	1	0	105
0	1	0	1	0	1	1	0	106
1	1	0	1	0	1	1	0	107
0	0	1	1	0	1	1	0	108
1	0	1	1	0	1	1	0	109
0	1	1	1	0	1	1	0	110
1	1	1	1	0	1	1	0	111
0	0	0	0	1	1	1	0	112
1	0	0	0	1	1	1	0	113
0	1	0	0	1	1	1	0	114
1	1	0	0	1	1	1	0	115
0	0	1	0	1	1	1	0	116
1	0	1	0	1	1	1	0	117
0	1	1	0	1	1	1	0	118
1	1	1	0	1	1	1	0	119
0	0	0	1	1	1	1	0	120
1	0	0	1	1	1	1	0	121
0	1	0	1	1	1	1	0	122
1	1	0	1	1	1	1	0	123
0	0	1	1	1	1	1	0	124
1	0	1	1	1	1	1	0	125
0	1	1	1	1	1	1	0	126
1	1	1	1	1	1	1	0	127

Table.3

Address Codes 128-159								
DIP1								Addr. Code
1	2	3	4	5	6	7	8	
0	0	0	0	0	0	0	1	128
1	0	0	0	0	0	0	1	129
0	1	0	0	0	0	0	1	130
1	1	0	0	0	0	0	1	131
0	0	1	0	0	0	0	1	132
1	0	1	0	0	0	0	1	133
0	1	1	0	0	0	0	1	134
1	1	1	0	0	0	0	1	135
0	0	0	1	0	0	0	1	136
1	0	0	1	0	0	0	1	137
0	1	0	1	0	0	0	1	138
1	1	0	1	0	0	0	1	139
0	0	1	1	0	0	0	1	140
1	0	1	1	0	0	0	1	141
0	1	1	1	0	0	0	1	142
1	1	1	1	0	0	0	1	143
0	0	0	0	1	0	0	1	144
1	0	0	0	1	0	0	1	145
0	1	0	0	1	0	0	1	146
1	1	0	0	1	0	0	1	147
0	0	1	0	1	0	0	1	148
1	0	1	0	1	0	0	1	149
0	1	1	0	1	0	0	1	150
1	1	1	0	1	0	0	1	151
0	0	0	1	1	0	0	1	152
1	0	0	1	1	0	0	1	153
0	1	0	1	1	0	0	1	154
1	1	0	1	1	0	0	1	155
0	0	1	1	1	0	0	1	156
1	0	1	1	1	0	0	1	157
0	1	1	1	1	0	0	1	158
1	1	1	1	1	0	0	1	159

Address Codes 160-191								
DIP1								Addr. Code
1	2	3	4	5	6	7	8	
0	0	0	0	0	1	0	1	160
1	0	0	0	0	1	0	1	161
0	1	0	0	0	1	0	1	162
1	1	0	0	0	1	0	1	163
0	0	1	0	0	1	0	1	164
1	0	1	0	0	1	0	1	165
0	1	1	0	0	1	0	1	166
1	1	1	0	0	1	0	1	167
0	0	0	1	0	1	0	1	168
1	0	0	1	0	1	0	1	169
0	1	0	1	0	1	0	1	170
1	1	0	1	0	1	0	1	171
0	0	1	1	0	1	0	1	172
1	0	1	1	0	1	0	1	173
0	1	1	1	0	1	0	1	174
1	1	1	1	0	1	0	1	175
0	0	0	0	1	1	0	1	176
1	0	0	0	1	1	0	1	177
0	1	0	0	1	1	0	1	178
1	1	0	0	1	1	0	1	179
0	0	1	0	1	1	0	1	180
1	0	1	0	1	1	0	1	181
0	1	1	0	1	1	0	1	182
1	1	1	0	1	1	0	1	183
0	0	0	1	1	1	0	1	184

6. Appendix A. Marking Description

CE Marking	
	<p>CE Marking on a product is a manufacturer's declaration that the product complies with the essential requirements of the relevant European health, safety and environmental protection legislation, in practice by many of the so-called Product Directives.</p>
Correct Disposal of this product	
	<p>This marking indicates that this product should not be disposed with other household wastes throughout the EU. To prevent possible harm to the environment or human health from uncontrolled waste disposal, recycle it responsibly to promote the sustainable reuse of material resources. To return your used device, please use the return and collection systems or contact the retailer where the product was purchased. They can take this product for environmental safe recycling.</p>

Thank you for Choosing



www.delta-dct.com



66129916181